

30UP WIZARD (inbouwversie)

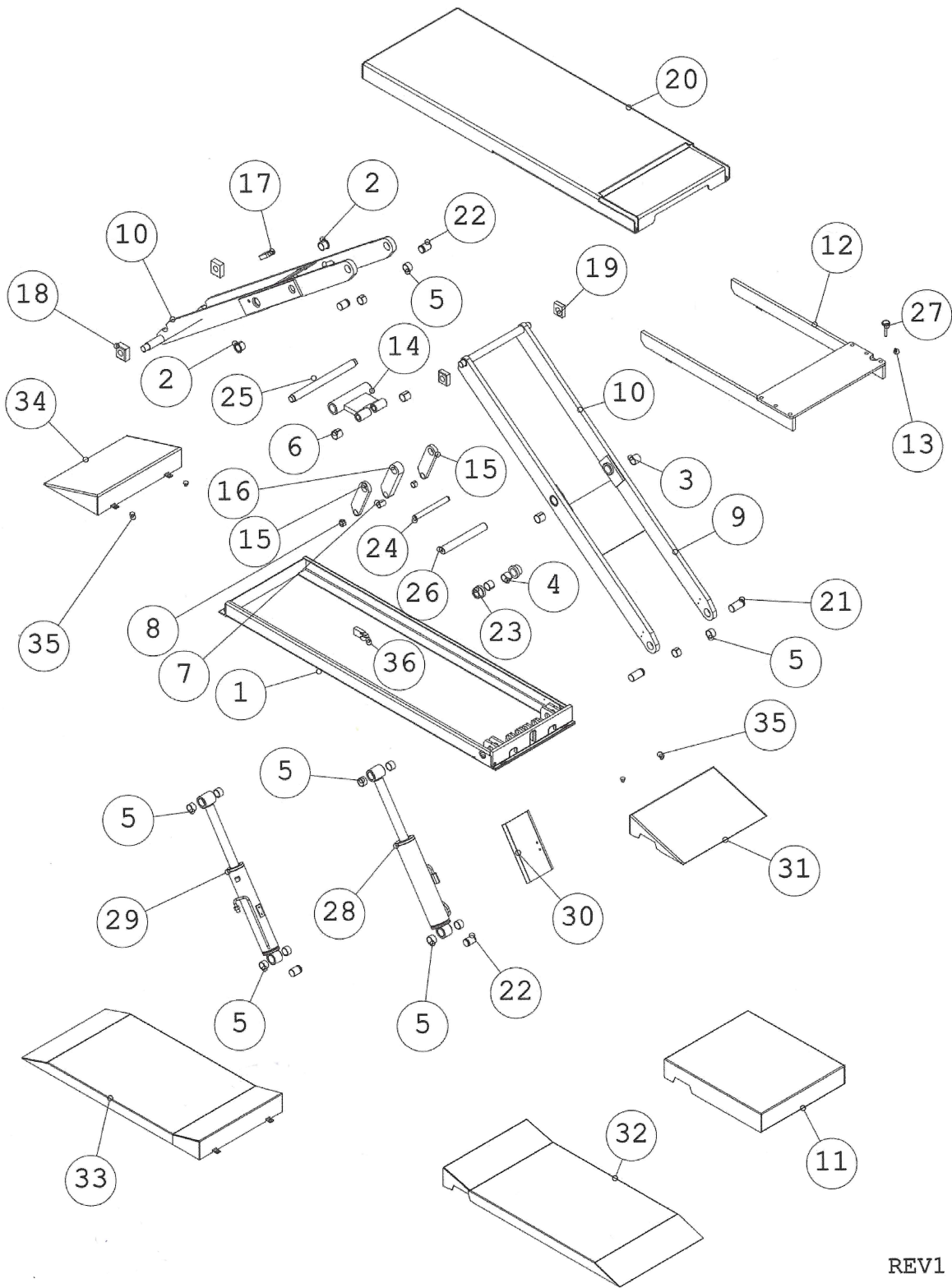

REV1

Pic. 16

30UP WIZARD

Posizione	Codice	Quantità	Descrizione
1	30UPW1000 BASE	2	BASE
2	BK1-30-26-F	4	BOCCOLE
3	BK1-30-30	4	BOCCOLE
4	BK1-30-25	4	BOCCOLE
5	BK1-30-20	24	BOCCOLE
6	BK1-30-30	4	BOCCOLE LEVA CENTRALE
7	BK1-20-30	2	BOCCOLE LEVE CENTRALI
8	BK1-20-15	4	BOCCOLE LEVE LATERALI
9	30UPW1200	2	BRACCIO ESTERNO
10	30UPW1100 REV1	2	BRACCIO INTERNO
11	30UPW1920	5	COPRISPAZIO
12	30UPW1510	2	ESTENSIONE
13	TCEI M-6X10 ZINCATO	2	ESTENSIONE
14	30UPW1600	8	LEVE
15	30UPW1610	4	LEVE
16	30UPW1620	2	LEVE
17	FF4512-2DN / NF B110FB-DC10	2	MICRO PISTONI + STOP ENDGO
18	30UPW1701	4	PATTINO BASE
19	30UPW1715	4	PATTINO PEDANA
20	30UPW1520	2	PEDANA
21	30UPW2006	4	PERNI
22	30UPW2004	8	PERNI
23	30UPW2000 REV1	4	PERNI
24	30UPW2002	2	PERNI
25	30UPW2003	2	PERNI
26	30UPW2001	2	PERNI
27	30UPW2005	2	PERNI
28	30UPW4000	2	PISTONE P1
29	30UPW4100	2	PISTONE P2
30	30UPW1800	2	PISTONI
31	30UPW1900	2	RAMPA ANTERIORE
32	30UPW1910	2	RAMPA LUNGA ANTERIORE
33	30UPW1911	2	RAMPA LUNGA POSTERIORE
34	30UPW1901	2	RAMPA POSTERIORE
35	TE M-10X10 ZINCATO	8	RAMPE
36	FF4552-2DN / NF B112KF-DC10	1	MICRO FINECORSA ALTO

REV1

30UP WIZARD FL

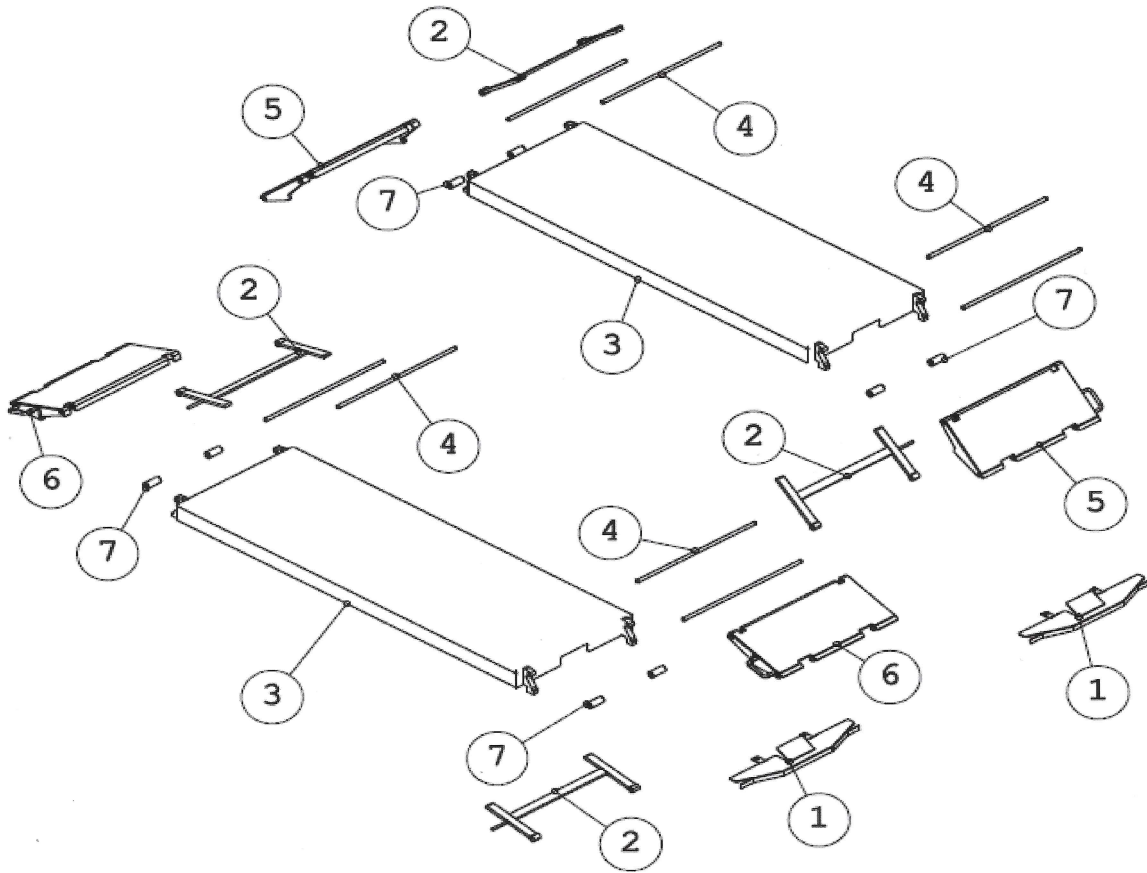

Posizione	Codice	Quantità	Descrizione
1	30UPW1000-10	2	COPRITUBO BASE
2	30UPW5001	4	FERMO PER RAMPETTA
3	30UPW1500	2	PEDANA CON FLAPS
4	30UPW5000-02	8	PERNO RAMPETTE
5	30UPW5000 DS	2	RAMPETTE
6	30UPW5000 SX	2	RAMPETTE
7	30UPW5000-09	8	RULLO RAMPETTA

Pos.	Code	Description	Q.ty
1	30UPW1000-10	BASE HOSE COVER	2
2	30UPW5001	RAMP STOP	4
3	30UPW1500	PLATFORM WITH FLAPS	2
4	30UPW5000-02	RAMPS PIN	8
5	30UPW5000 DS	RAMPS	2
6	30UPW5000 SX	RAMPS	2
7	30UPW5000-09	RAMPS ROLLER	8

Tabella distinta materiali		6	7	8
Num. articolo	Num. parte	DENOMINAZIONE		Quantità
1	SS15050KEL10	Collettore HELIO (SDV-FSC reg)		1
2	B0035806	Tappo ad espansione a sferra HP		1
3	BC114611	Anello O-Ring HER 70Sh. 112.00x3.00		1
4	FT33065160	Valvola max VMC3 360 Bar		1
5	FT32005	Valvola unidirezionale VUL		1
6	FT49002	TSL-Tappo 3/4-16UNF, Ø12.7 - att. 1/4", Avvitale		1
7	SS577000000	Flangia x TPO4 (RP-AC), MEC30		1
8	SS506320014	Giunto x TPO4 (RP-AC) MEC30		1
9	SS506320013	Semi-giunto x TPO3-04-05 (RP-AC)		1
10	BC10914.20008	Pompa grl - 4,20cc - S - 302 SX		1
11	FT46003	STP-Valvola start-up 3T		1
12	SS52301104	Tubo di servizio 5x. M12x1.500		2
13	SS5063500001	Filtro aspirazione polipropilene 3/8" RSPF		1
14	SS512036	Scrubatoio pl. 2x 9 vert 8315		1
15	BC12735001	Tappo sfiato carico olio 1/2"		1
16	FT51019	Blocco con 2 rit. 2 Vh. VSP 12 6UT		1
17	FT49003	TC2-Tappo 3/4 - 16UNF, R=12,5		1
18	FT451892	Blocco Mod. B92 - Distanziante R=25		1
19	SS524AM230	80230-Tubo di aspirazione pl. 3/8" L=230		1
20	FT49005	TC1-Tappo x cavità STP, files. M10		1
21	ES4132000002	Dado speciale triang. M6		4

INT.	DESCRIZIONE	MODIFICAZIONE	REVISIONE	DATA	CAUSA DELLA MODIF. O VALORAZIONE	SCALA
1	ES4132000002	21/07/2003	1	2003		1:5
2	FT49005	21/07/2003	1	2003		
3	FT49003	21/07/2003	1	2003		
4	FT49002	21/07/2003	1	2003		
5	FT33065160	21/07/2003	1	2003		
6	FT32005	21/07/2003	1	2003		
7	FT46003	21/07/2003	1	2003		
8	FT51019	21/07/2003	1	2003		
9	FT451892	21/07/2003	1	2003		
10	FT49003	21/07/2003	1	2003		
11	FT52301104	21/07/2003	1	2003		
12	FT5063500001	21/07/2003	1	2003		
13	FT512036	21/07/2003	1	2003		
14	FT12735001	21/07/2003	1	2003		
15	FT10914.20008	21/07/2003	1	2003		
16	FT106320014	21/07/2003	1	2003		
17	FT106320013	21/07/2003	1	2003		
18	FT10914.20008	21/07/2003	1	2003		
19	FT106320014	21/07/2003	1	2003		
20	FT106320013	21/07/2003	1	2003		
21	FT10914.20008	21/07/2003	1	2003		

INT.	DESCRIZIONE	MODIFICAZIONE	REVISIONE	DATA	CAUSA DELLA MODIF. O VALORAZIONE	SCALA
1	ES4132000002	21/07/2003	1	2003		1:5
2	FT49005	21/07/2003	1	2003		
3	FT49003	21/07/2003	1	2003		
4	FT49002	21/07/2003	1	2003		
5	FT33065160	21/07/2003	1	2003		
6	FT32005	21/07/2003	1	2003		
7	FT46003	21/07/2003	1	2003		
8	FT51019	21/07/2003	1	2003		
9	FT451892	21/07/2003	1	2003		
10	FT49003	21/07/2003	1	2003		
11	FT52301104	21/07/2003	1	2003		
12	FT5063500001	21/07/2003	1	2003		
13	FT512036	21/07/2003	1	2003		
14	FT12735001	21/07/2003	1	2003		
15	FT10914.20008	21/07/2003	1	2003		
16	FT106320014	21/07/2003	1	2003		
17	FT106320013	21/07/2003	1	2003		
18	FT10914.20008	21/07/2003	1	2003		
19	FT106320014	21/07/2003	1	2003		
20	FT106320013	21/07/2003	1	2003		
21	FT10914.20008	21/07/2003	1	2003		

INT.	DESCRIZIONE	MODIFICAZIONE	REVISIONE	DATA	CAUSA DELLA MODIF. O VALORAZIONE	SCALA
1	ES4132000002	21/07/2003	1	2003		1:5
2	FT49005	21/07/2003	1	2003		
3	FT49003	21/07/2003	1	2003		
4	FT49002	21/07/2003	1	2003		
5	FT33065160	21/07/2003	1	2003		
6	FT32005	21/07/2003	1	2003		
7	FT46003	21/07/2003	1	2003		
8	FT51019	21/07/2003	1	2003		
9	FT451892	21/07/2003	1	2003		
10	FT49003	21/07/2003	1	2003		
11	FT52301104	21/07/2003	1	2003		
12	FT5063500001	21/07/2003	1	2003		
13	FT512036	21/07/2003	1	2003		
14	FT12735001	21/07/2003	1	2003		
15	FT10914.20008	21/07/2003	1	2003		
16	FT106320014	21/07/2003	1	2003		
17	FT106320013	21/07/2003	1	2003		
18	FT10914.20008	21/07/2003	1	2003		
19	FT106320014	21/07/2003	1	2003		
20	FT106320013	21/07/2003	1	2003		
21	FT10914.20008	21/07/2003	1	2003		

INT.	DESCRIZIONE	MODIFICAZIONE	REVISIONE	DATA	CAUSA DELLA MODIF. O VALORAZIONE	SCALA
1	ES4132000002	21/07/2003	1	2003		1:5
2	FT49005	21/07/2003	1	2003		
3	FT49003	21/07/2003	1	2003		
4	FT49002	21/07/2003	1	2003		
5	FT33065160	21/07/2003	1	2003		
6	FT32005	21/07/2003	1	2003		
7	FT46003	21/07/2003	1	2003		
8	FT51019	21/07/2003	1	2003		
9	FT451892	21/07/2003	1	2003		
10	FT49003	21/07/2003	1	2003		
11	FT52301104	21/07/2003	1	2003		
12	FT5063500001	21/07/2003	1	2003		
13	FT512036	21/07/2003	1	2003		
14	FT12735001	21/07/2003	1	2003		
15	FT10914.20008	21/07/2003	1	2003		
16	FT106320014	21/07/2003	1	2003		
17	FT106320013	21/07/2003	1	2003		
18	FT10914.20008	21/07/2003	1	2003		
19	FT106320014	21/07/2003	1	2003		
20	FT106320013	21/07/2003	1	2003		
21	FT10914.20008	21/07/2003	1	2003		

INT.	DESCRIZIONE	MODIFICAZIONE	REVISIONE	DATA	CAUSA DELLA MODIF. O VALORAZIONE	SCALA
1	ES4132000002	21/07/2003	1	2003		1:5
2	FT49005	21/07/2003	1	2003		
3	FT49003	21/07/2003	1	2003		
4	FT49002	21/07/2003	1	2003		
5	FT33065160	21/07/2003	1	2003		
6	FT32005	21/07/2003	1	2003		
7	FT46003	21/07/2003	1	2003		
8	FT51019	21/07/2003	1	2003		
9	FT451892	21/07/2003	1	2003		
10	FT49003	21/07/2003	1	2003		
11	FT52301104	21/07/2003	1	2003		
12	FT5063500001	21/07/2003	1	2003		
13	FT512036	21/07/2003	1	2003		
14	FT12735001	21/07/2003	1	2003		
15	FT10914.20008	21/07/2003	1	2003		
16	FT106320014	21/07/2003	1	2003		
17	FT106320013	21/07/2003	1	2003		
18	FT10914.20008	21/07/2003	1	2003		
19	FT106320014	21/07/2003	1	2003		
20	FT106320013	21/07/2003	1	2003		
21	FT10914.20008	21/07/2003	1	2003		

INT.	DESCRIZIONE	MODIFICAZIONE	REVISIONE	DATA	CAUSA DELLA MODIF. O VALORAZIONE	SCALA
1	ES4132000002	21/07/2003	1	2003		1:5
2	FT49005	21/07/2003	1	2003		
3	FT49003	21/07/2003	1	2003		
4	FT49002	21/07/2003	1	2003		
5	FT33065160	21/07/2003	1	2003		
6	FT32005	21/07/2003	1	2003		
7	FT46003	21/07/2003	1	2003		
8	FT51019	21/07/2003	1	2003		
9	FT451892	21/07/2003	1	2003		
10	FT49003	21/07/2003	1	2003		
11	FT52301104	21/07/2003	1	2003		
12	FT5063500001	21/07/2003	1	2003		
13	FT512036	21/07/2003	1	2003		
14	FT12735001	21/07/2003	1	2003		
15	FT10914.20008	21/07/2003	1	2003		
16	FT106320014	21/07/2003	1	2003		
17	FT106320013	21/07/2003	1	2003		
18	FT10914.20008	21/07/2003	1	2003		
19	FT106320014	21/07/2003	1	2003		
20	FT106320013	21/07/2003	1	2003		
21	FT10914.20008	21/07/2003	1	2003		

INT.	DESCRIZIONE	MODIFICAZIONE	REVISIONE	DATA	CAUSA DELLA MODIF. O VALORAZIONE	SCALA
1	ES4132000002	21/07/2003	1	2003		1:5
2	FT49005	21/07/2003	1	2003		
3	FT49003	21/07/2003	1	2003		
4	FT49002	21/07/2003	1	2003		
5	FT33065160	21/07/2003	1	2003		
6	FT32005	21/07/2003	1	2003		
7	FT46003	21/07/2003	1	2003		
8	FT51019	21/07/2003	1	2003		
9	FT451892	21/07/2003	1	2003		
10	FT49003	21/07/2003	1	2003		
11	FT52301104	21/07/2003	1	2003		
12	FT5063500001	21/07/2003	1	2003		
13	FT512036	21/07/2003	1	2003		
14	FT12735001	21/07/2003	1	2003		
15	FT10914.20008	21/07/2003	1	2		

CONTROL BOX

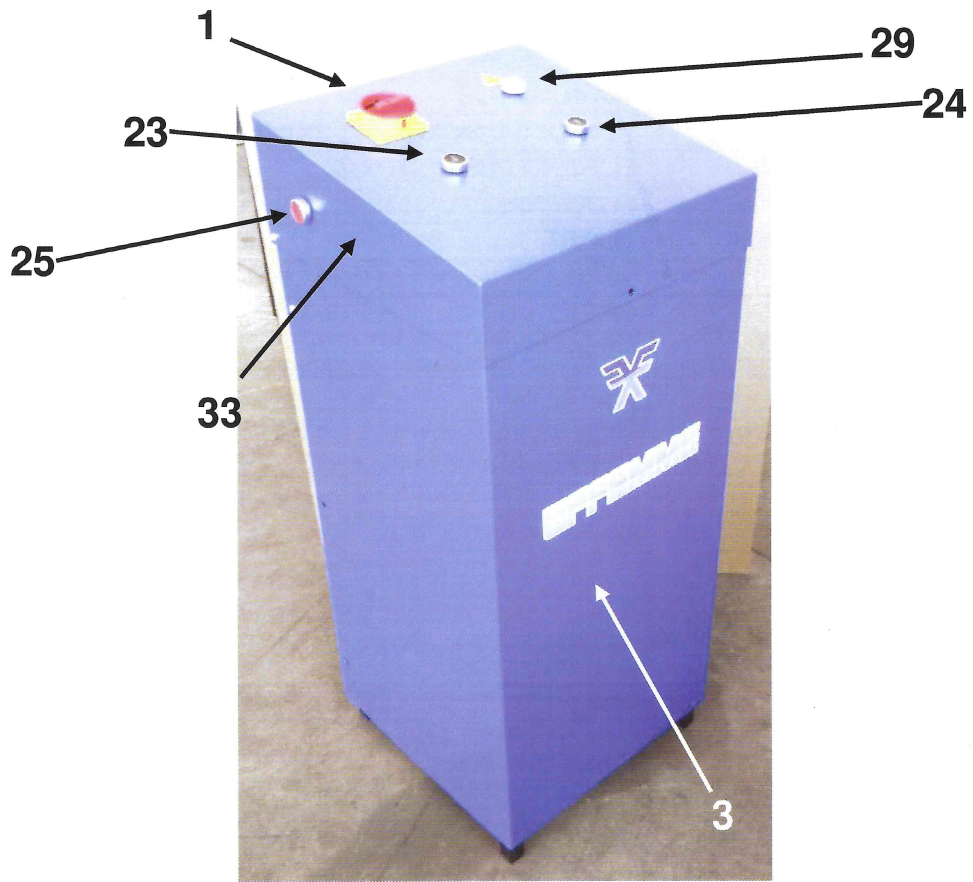

Pic. 20 a

Pic. 20 b

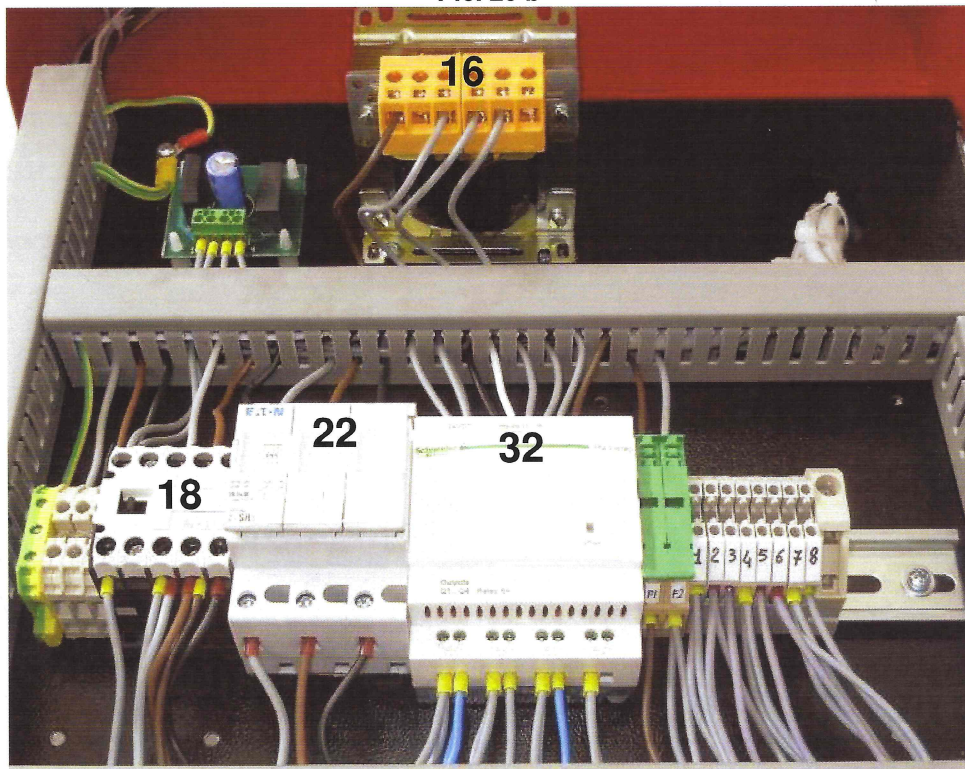

Pos.	Code	Description	Q.ty
1	06-6000	MAIN SWITCH	1
3	30UP3000	CABINET	1
16	06-6002	TRANSFORMER 50VA 24 V	1
18	06-6004	CONTACTOR	1
22	06-6009	DIN GUIDE 3x32A FUSE HOLDER	1
23	06-6010	LIFTING PUSH BUTTON	1
24	06-6011	LOWERING PUSH BUTTON	1
29	06-6016	LIGHT	1
25	EF	EXCLUSION END STROKE MAX HEIGHT MICRO	1
32	PLC	PLC	1
33	30UP3002	TOP COVER	1

MICROS



Pic.22
MR4 End stroke height micro

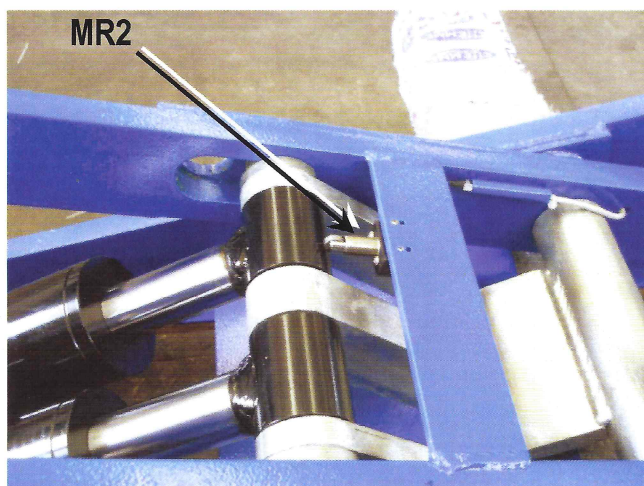

Pic. 23
P1 cylinder position sensing micro

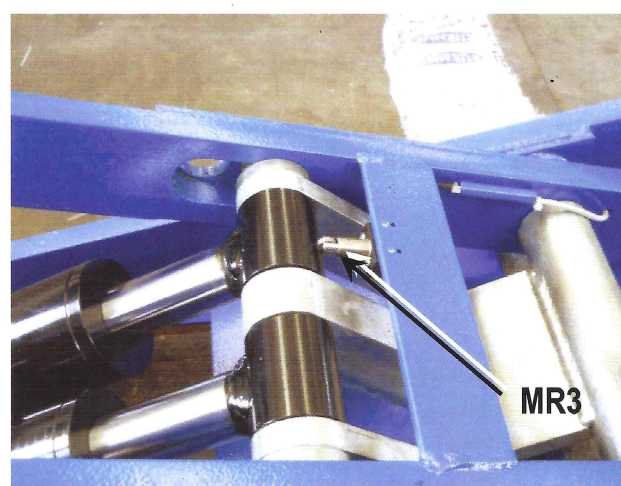

Pic. 24
P2 cylinder position sensing micro

Connect or	Pict.	Indic.	Part N.	Type	Description
JP 3	Pic. 22	MR4	06-5012	FF4552	End stroke height micro
JP 17	Pic. 23	MR2	06-5011	FF4512	P1 cylinder position sensing micro
JP 18	Pic.24	MR3	06-5011	FF4512	P2 cylinder position sensing micro